

Uses of radiation

- 1 The diagram shows light from a point source, **S**, spreading out as it gets further from **S**.

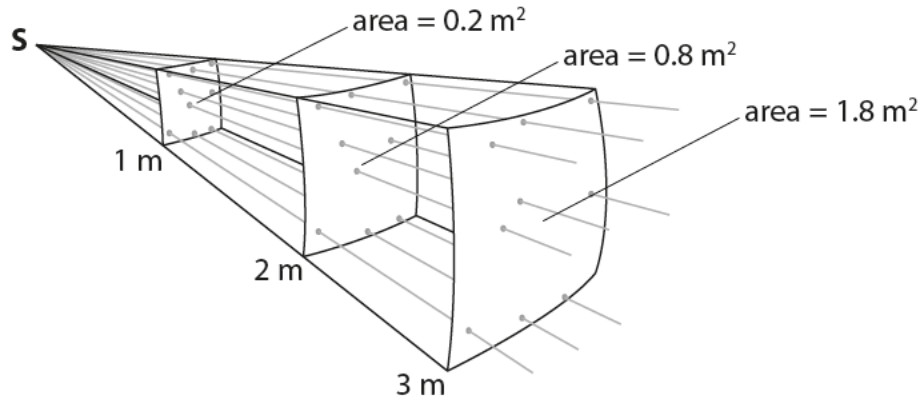

- (a) The intensity of light passing through the surface which is 1 m from **S** is 2.5 W/m².

- (i) Complete the sentence by putting a cross (☒) in the box next to your answer.

The intensity of light, in W/m², passing through the surface which is 2 m from **S** is

(1)

- A** 2.5
- B** 2.5
- C** 2.5
- D** 2.5

- (ii) Calculate the power of the light passing through the surface which is 1m from **S**.

(2)

power = W

(b) The graph shows how the intensity of ultrasound waves of different frequencies decreases as they penetrate soft tissue.

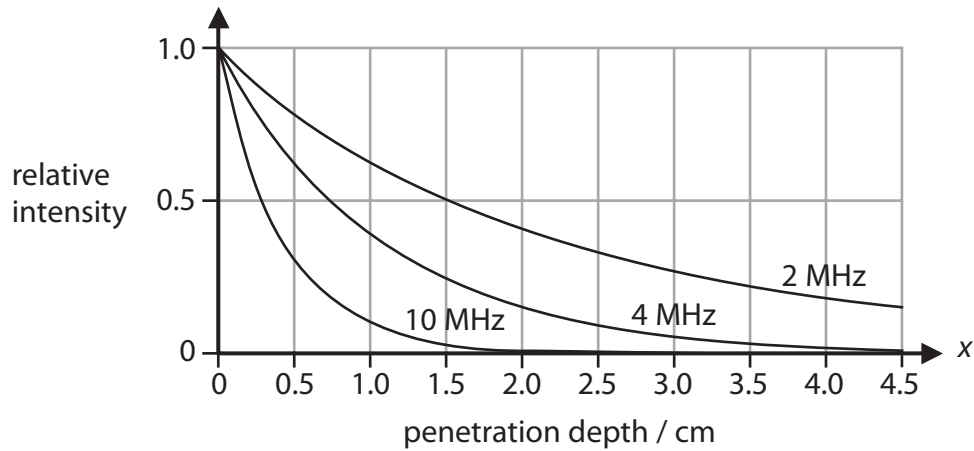

(i) Estimate how far a 2 MHz wave has penetrated into the soft tissue when its intensity is 25% of its original value.

(1)

penetration depth = cm

(ii) Explain which of these frequencies of ultrasound can be used to scan organs deep inside the body.

(2)

.....

.....

.....

.....

*(c) Medical physicists have developed endoscopes and many other devices to help doctors diagnose medical problems.

Compare the use of electromagnetic radiation in endoscopes and in one other diagnostic device.

(6)

.....

.....

.....

.....

.....

.....

.....

.....

.....

.....

.....

.....

.....

.....

.....

.....

.....

.....

.....

.....

.....

.....

.....

(Total for Question 5 = 12 marks)

Running like clockwork

- 2 The diagram shows Simon's clock.
Once a week, Simon turns a key to tighten the spring.
The spring uncoils slowly to keep the clock working.



- (a) Which type of energy is stored in the tightened spring?

Put a cross (☒) in the box next to your answer.

(1)

- A chemical energy
- B elastic potential energy
- C gravitational potential energy
- D thermal energy

- (b) Every hour, the
The clock lifts a small hammer.
The hammer falls and rings a little bell.

The diagram shows what happens to the energy from the falling hammer.

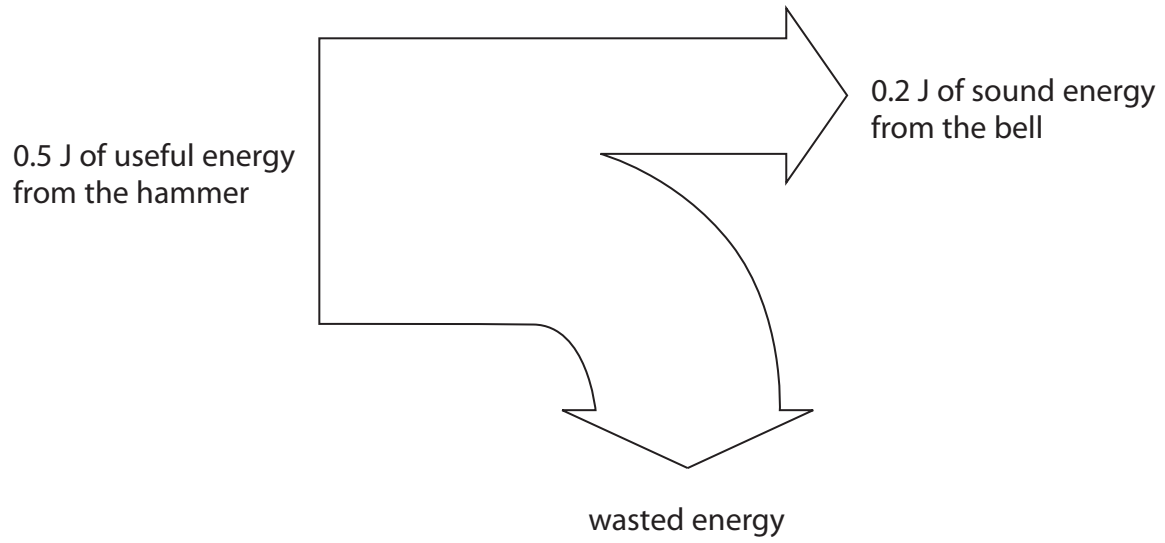

- (i) Calculate the energy wasted.

(1)

wasted energy = J

- (ii) Calculate the efficiency of this process.

(2)

efficiency =

(iii) Suggest what happens to the wasted energy.

(2)

*(c) The clock use
The pendulum is a metal rod with a large mass at the end.
The mass swings from side to side.

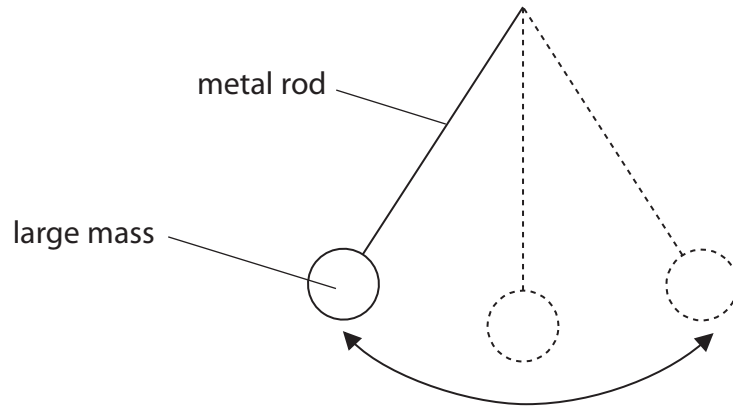

The spring keeps the pendulum swinging without stopping.

Describe the energy changes that happen as the pendulum continues to swing from side to side.

(6)

.....

.....

.....

.....

.....

.....

.....

.....

.....

.....

.....

.....

.....

.....

.....

.....

.....

.....

.....

.....

.....

.....

.....

(Total for Question 5 = 12 marks)

Water skiing

3 The photograph shows a water skier being pulled along by a boat.



(a) The diagram shows the horizontal forces acting on the water skier.

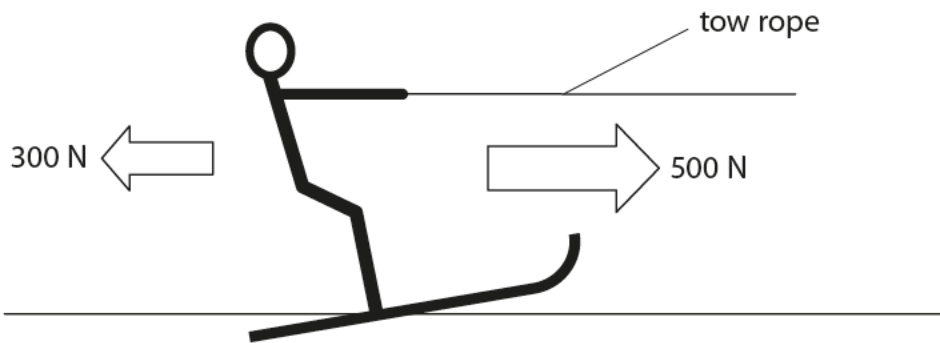

(i) The 500 N force is the force that the boat tow rope is exerting on the water skier.

Suggest what causes the 300 N force.

(1)

(ii) Calculate the resultant of these two forces.

(2)

resultant force = N

(iii) State the direction of the resultant of these two forces.

(1)

- (b) The diagram shows the water skier using a ramp to perform a jump. During the jump, she gains gravitational potential energy.

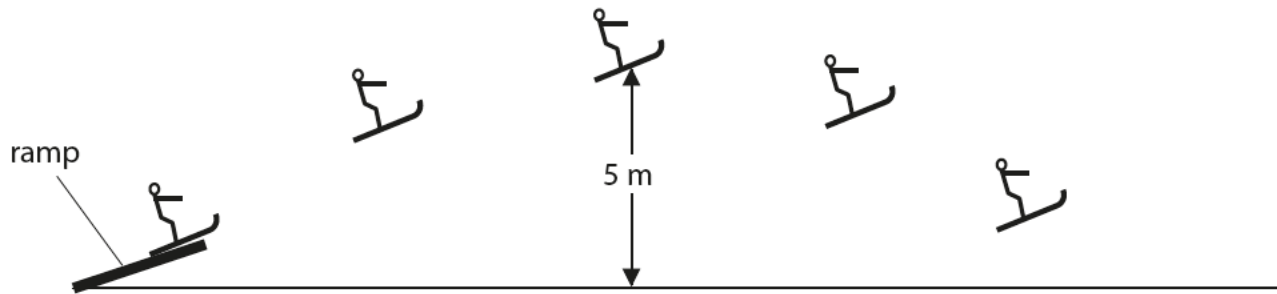

- (i) Complete the sentence by putting a cross (☒) in the box next to your answer.

The unit of gravitational potential energy is

(1)

- A A
- B J
- C N
- D W

- (ii) The mass of the water skier is 54 kg.

At the top of the jump, she is 5 m above the water level.

Calculate the amount of gravitational potential energy she gains in rising 5 m.

Gravitational field strength = 10 N/kg

(2)

gain in gravitational potential energy =

(iii) When the water skier reaches the top of the ramp, she lets go of the rope.

Describe the energy changes that happen between the skier leaving the ramp and reaching the top of the jump.

(2)

.....

.....

.....

.....

(Total for Question 3 = 9 marks)

Weight lifting

4 The picture shows a weight lifter.



(a) In one lift, he does 5040 J of work against gravity.

(i) One lift takes 4 seconds.

Complete the sentence by putting a cross (☒) in a box next to your answer.

The power used to lift the weight is

(1)

- A** 1260 W
- B** 2016 W
- C** 12600 W
- D** 20160 W

(ii) The weight he lifts has a mass of 240 kg.

Gravitational Field Strength = 10 N/Kg

The energy gained by the mass is equal to the work done when lifting it.

Calculate the height he lifts this mass.

(3)

height = m

- (b) After lifting the mass, he must hold it steady for 3 seconds.
During this time, he does no work on the mass.

State why he does no work on the mass in this time.

(1)

- (c) After the 3 seconds, the weight lifter drops the mass.
The velocity of the mass just before it hits the floor is 6.4 m/s.

Calculate the momentum of the mass just before it hits the floor.
State the unit.

(3)

momentum = unit =

(Total for Question 1 = 8 marks)